

RNR20 FLEXARM TAPPER

WORKING RANGE 15"-72"

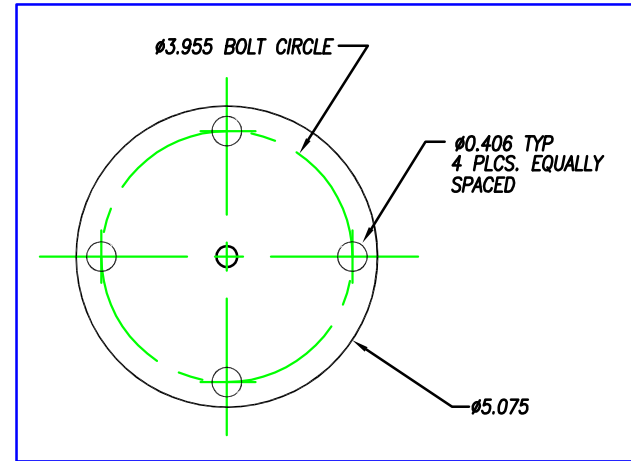
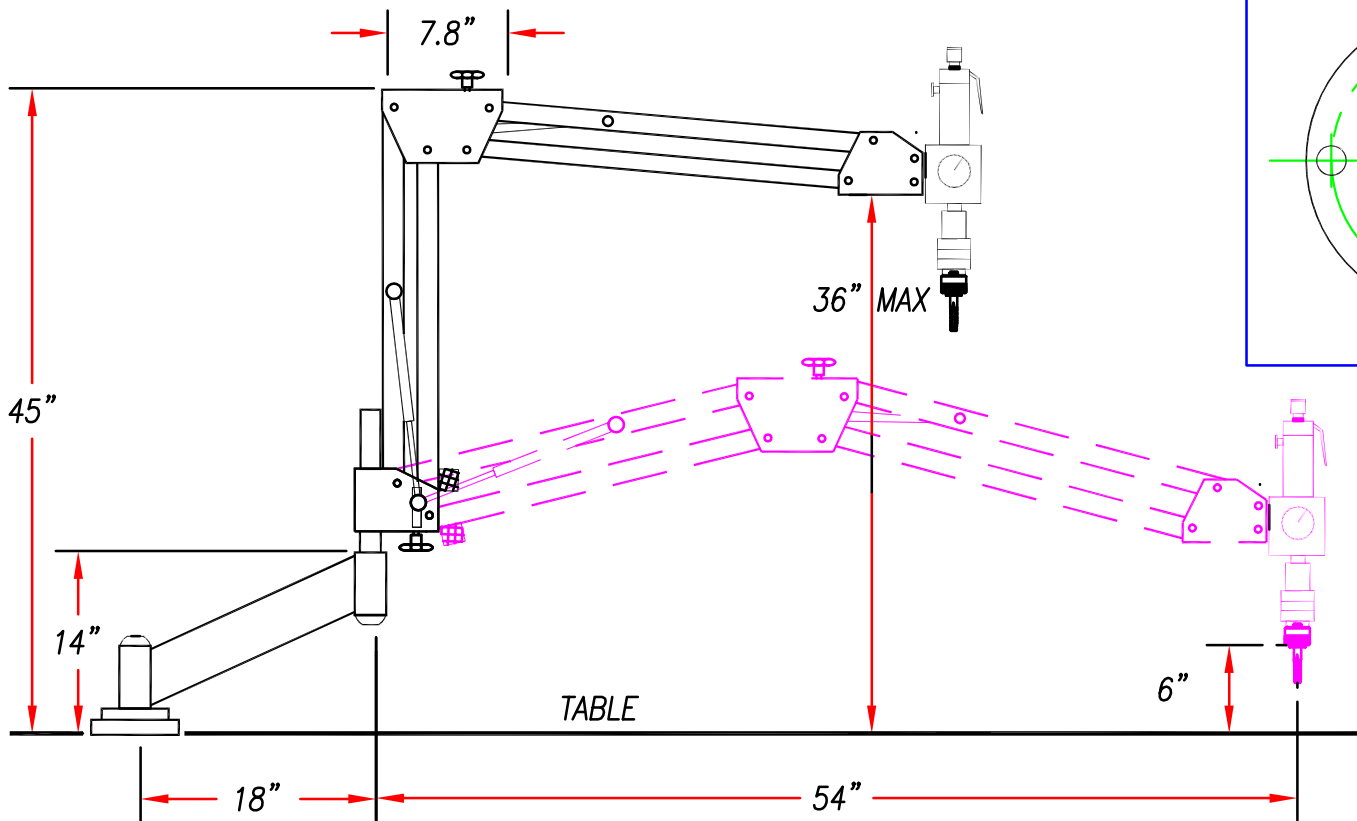

- * STANDARD UNIT INCLUDES MOTOR, HOSE, 2 SPEED GEARBOX, FILTER/LUBRICATOR AND SIZE 2 CHUCK.
- * ARM INCLUDES ANGLE MOUNT AND BASE MOUNT.
- * MAX TAP CAPACITY IS 3/4" WITH 600RPM AND 7/8" WITH 400RPM (IN MILD STEEL)